



FILLER BREATHER ASSEMBLY

Model	Strainer Material
FB-700-TT-40	Plastic or MS or SS
FB-250-TT-40	
FBN 700 TT 40	
FB 700 SM 40	
FBN 700 SM 40	
FB 250 SM 40	

- This is a combination unit for filtering air displacement from the reservoir and for straining oil while filling.
- Mounting options include Tank Top and Side Mounting.
- The displacement capacity is 250 LPM and 700 LPM and filtration is up to 40 microns the air displacement from underneath the cap assembly improves performance.
- Specially designed slots provide for an extremely large amount of airflow through the cap.
- Nylon strainer with a guard stronger than conventional materials will not corrode.
- Filtration up to 5 microns available (Standard supply: 40 microns).
- All parts included in one package ready to install.

Model	Dimensions (mm)							
	ØA	ØB	ØC	ØD	E	F	G	Ø PCD
FB-700-TT-40	82.5	78	50	82.5	152	95	57	72
FB-250-TT-40	50.5	44	28	50.5	112	64	48	41
FBN 700 TT 40	90	78	50	82.5	155	95	45	72

HYDAX HYDRAULICS PVT. LTD.

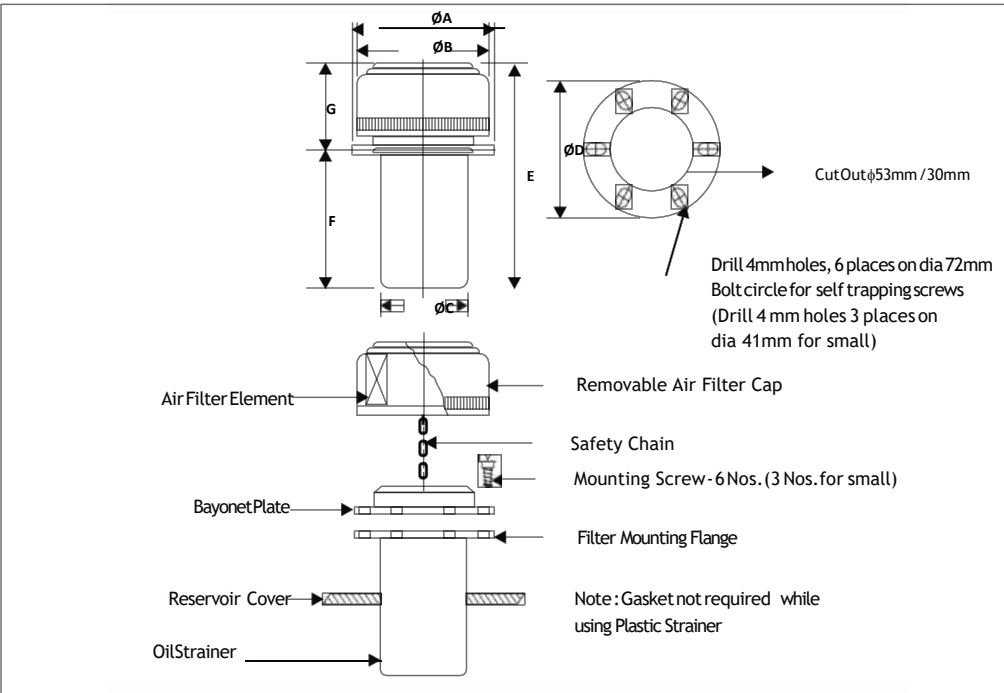

FB-700-TT-40 and FB-250-TT-40

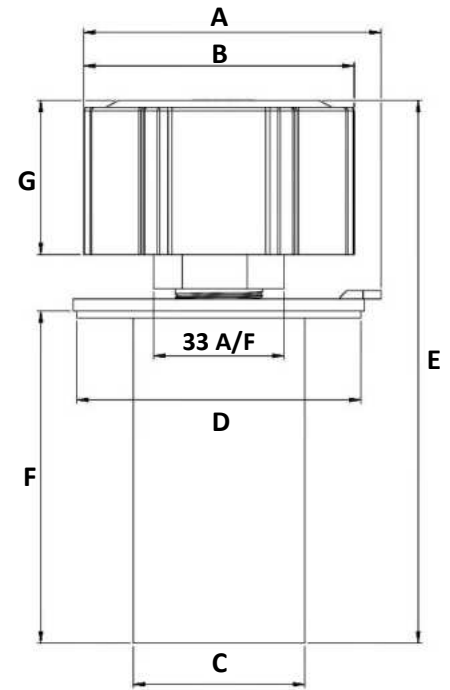

FBN-700-TT-40

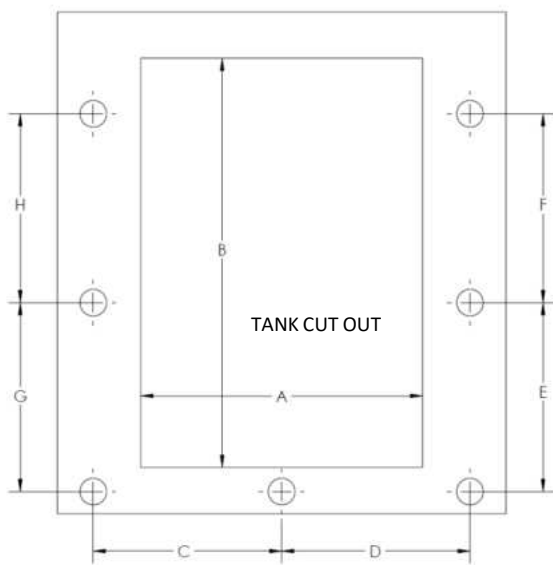

Details for side mounting
FB/FBN 700 SM 40

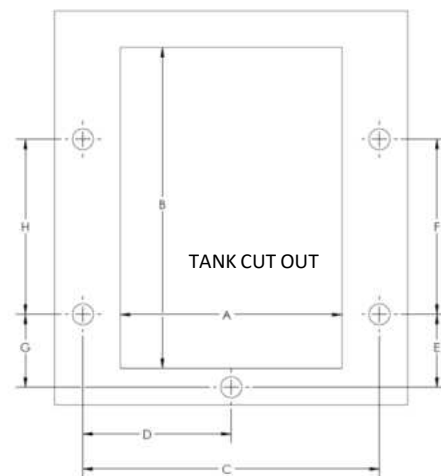

Details for side mounting
FB 250 SM 40

Model	A	B	C	D	E	F	G	H
FB250 SM 40	50	75	50.8	50.8	50.8	50.8	50.8	50.8
FB700 SM 40	82	115	74.5	37.25	18.5	48.5	18.5	48.5